



# ENVELOPE 2000<sup>®</sup>

REVEAL (RV) SYSTEM

**The Ultimate in Performance  
in a Field-Assembled System**

## TECHNICAL MANUAL

- System Assembly
- Substrate Layouts
- CAD Sections/Details
- Physical Properties
- Performance Properties

# SYSTEM ASSEMBLY

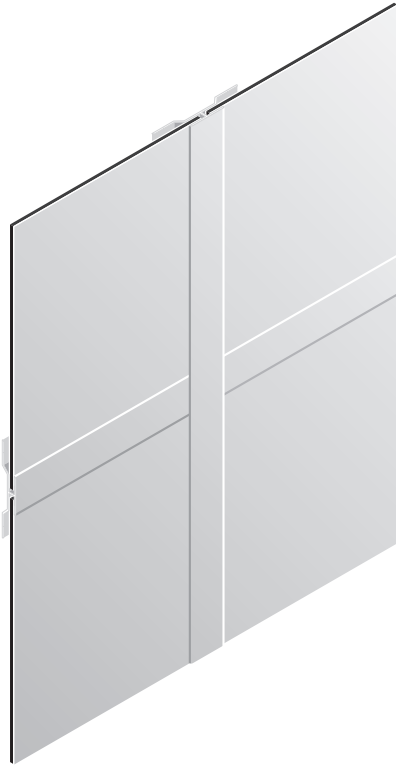

BATTEN PROFILES



REVEAL PROFILES

## MOLDINGS / EXTRUSIONS

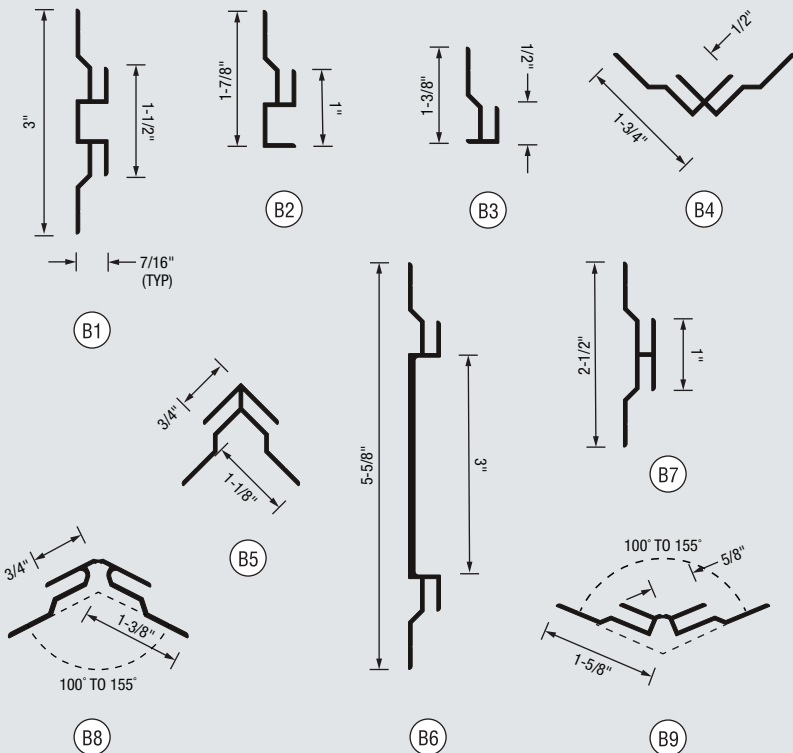

## PROPERTIES

- B1** CRAX-1 Horizontal/Vertical (Reveal)  
12'-6," 3.56 lbs
- B2** CRAX-2 Perimeter J (Reveal)  
12'-6," 2.25 lbs
- B3** CRAX-3 Perimeter J  
12'-6," 1.69 lbs
- B4** CRAX-4 Inside Corner  
12'-6," 3.00 lbs
- B5** CRAX-5 Outside Corner  
12'-6," 3.19 lbs
- B6** CRAX-6 Horizontal/Vertical (Reveal)  
12'-6," 8.06 lbs
- B7** CRAX-7 Horizontal/Vertical  
12'-6," 2.81 lbs
- B8** CRAX-8 Outside Corner (Adjustable)  
12'-6," 4.13 lbs
- B9** CRAX-9 Inside Corner (Adjustable)  
12'-6," 3.00 lbs

# SUBSTRATE LAYOUT

## NAILABLE SUBSTRATE

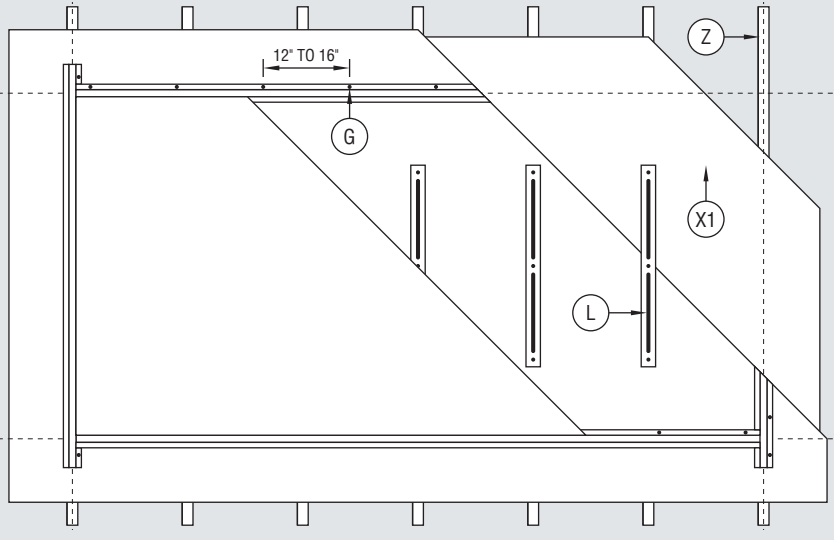

## NON-NAILABLE SUBSTRATE

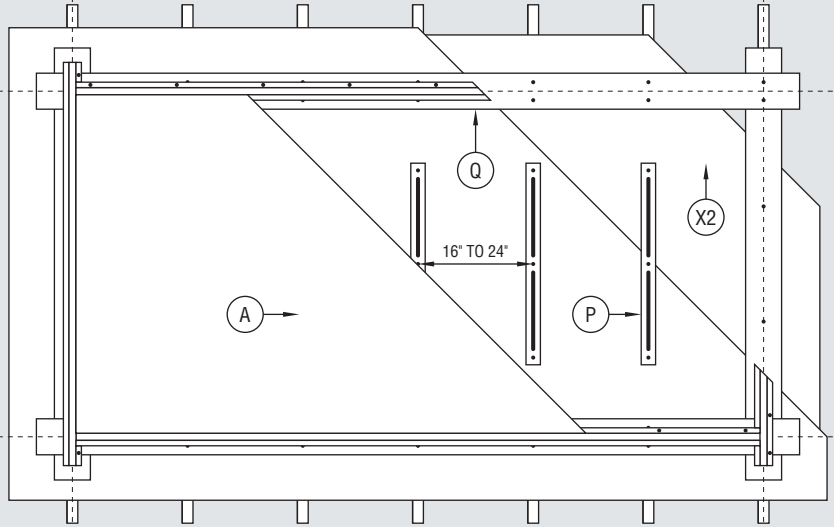

## MASONRY SUBSTRATE

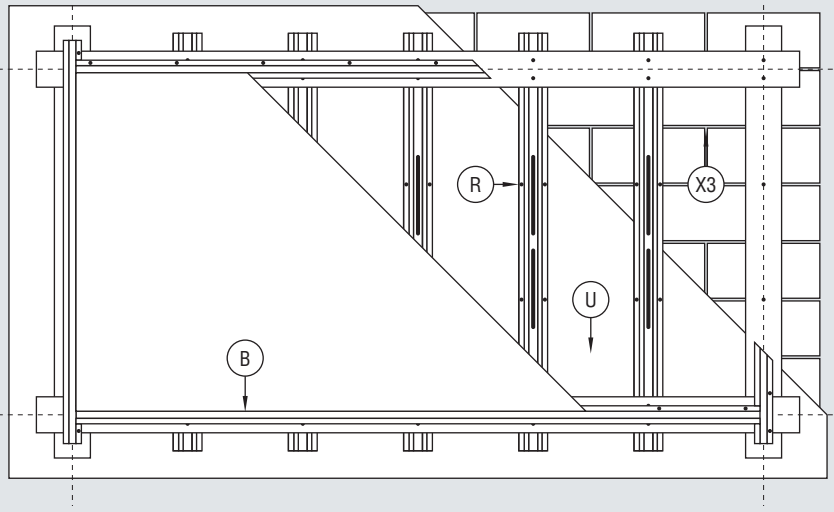

## COMPONENTS

- A** Envelope 2000
- B** Molding
- G** Fastener  
As selected by contractor to suit project requirements.
  - Panel - secured by sealant/adhesive
  - Molding - 12" to 16" along length
- L** Construction Adhesive  
An approved adhesive must be used. Contact Citadel for current list.
  - Located 16" to 24" o.c.
  - 3/8" bead x 2/3 panel height
  - For panels 36" x 36" or larger
- P** Field Strapping
  - Located 16" to 24" o.c.
  - 1-1/2" (min) x 2/3 panel height
  - 22ga (min) recommended
  - Fastened 12" to 16" along length
- Q** Grid Strapping
  - 16ga (min) recommended
  - Fastened 12" to 16" along length
- R** Furring
  - Metal (hat channels, z-girts) or wood
  - Located 16" to 24" o.c.
  - Fastened 12" to 16" along length
- S** Shim (not shown)
  - Plastic shims recommended
  - Flatness tolerance is 1/4" in 20'-0"
- U** Air/Moisture Barrier  
Recommended for this system.
- X1** Nailable Substrate
  - Plywood - 1/2" (min) recommended
  - OSB - 1/2" (min) recommended
- X2** Non-Nailable Substrate
  - Exterior gypsum board
- X3** Masonry Substrate
  - CMU (block)
  - Pre-formed concrete
- Z** Stud Framework
  - Metal or wood
  - Located 16" to 24" o.c.

NOTE: Combine both SECTION and SUBSTRATE drawings for a complete listing of components.

# LAYOUT AND INSTALLATION

## DESCRIPTION

- **Field Assembled** - all panels and moldings are shipped directly to the jobsite and are cut-to-size in the field, saving significant time and money.
- **Barrier Wall** - designed to be completely sealed against moisture intrusion to protect the structural wall assembly of the building.
- **Progressive** - each step of the installation process builds off the previous step in a sequential manner, moving up and across the elevation.
- **Joints** - one piece aluminum moldings capture the panel edges and may be color matched or painted a complimentary color.

### Comparative Installed Cost



**Lead Time:** 15 working days  
**Minimum Qty:** none  
**System Depth:** 7/16" from the face of the substrate to the face of the molding

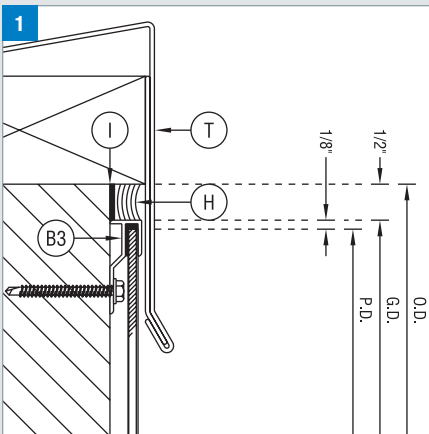

## HORIZONTAL SECTIONS

### 1: Parapet

Metal flashing secured over blocking completes the vertical run and prevents moisture from getting behind the system.

### 2A, 2B & 2C: Horizontal

Sealant is applied into the molding channel and slid over the top of the mounted panel. More sealant is then applied into the top channel of the molding and fasteners are then placed in the top leg of the extrusion. Batten or reveal (1/2" or 3") profile.

### 3A & 3B: Base/Foundation

Installation typically begins at the base of the wall and moves vertically. The cladding should be kept approximately 12" away from landscaping grade. However, if the system is installed adjacent to a concrete sidewalk, that dimension may be reduced to 1/2"

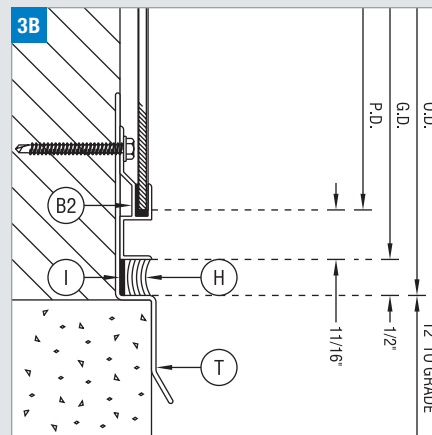
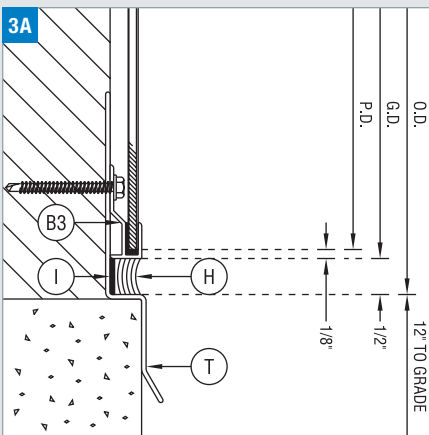
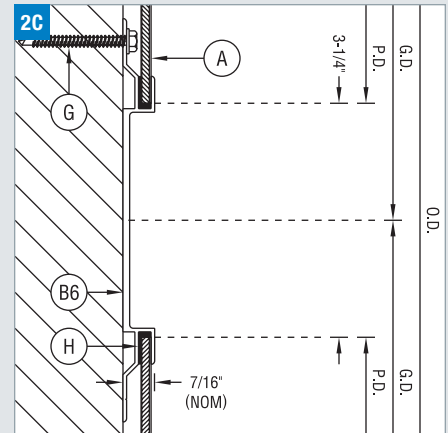
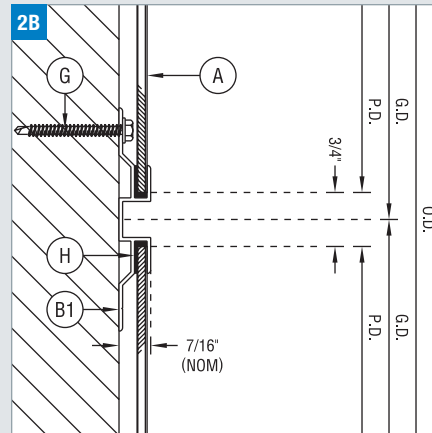
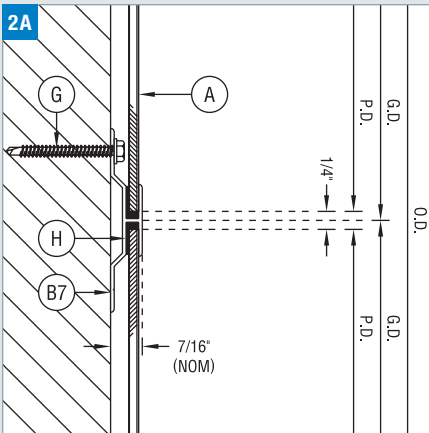

# LAYOUT AND INSTALLATION

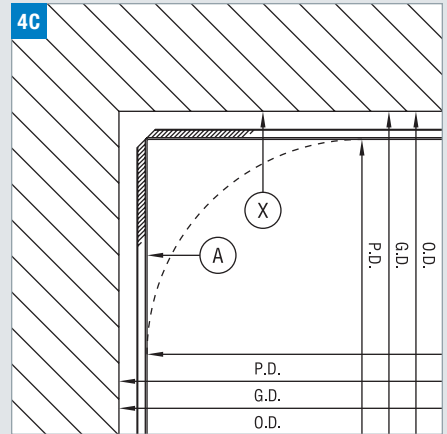
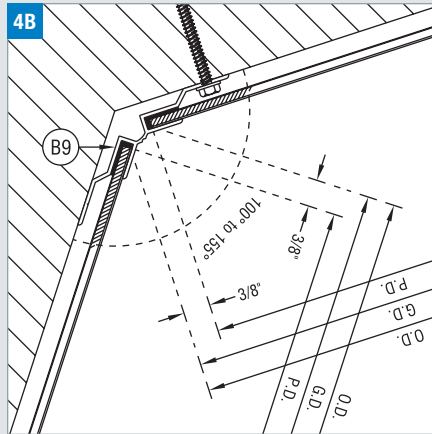
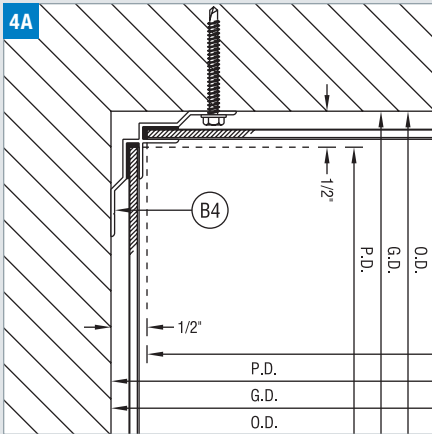

## INSIDE CORNER

### 4A, 4B & 4C: Inside Corner

The corner molding is slid over the panel edge after sealant has been applied. Then the lead leg is mechanically fastened. The next panel in the sequence inserted into the molding after sealant is placed in the channel. As an option for non-standard corners, the adjustable molding may be used and bent to the correct angle. Or, panels may also be routed on the back side and bent to form the corner.

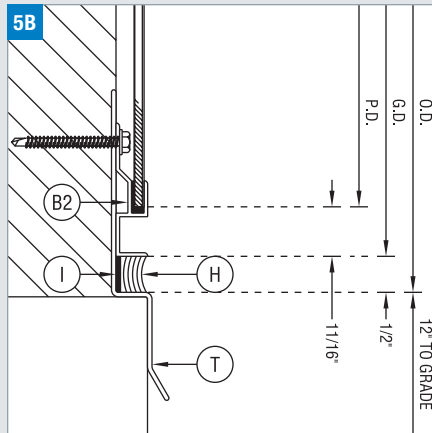
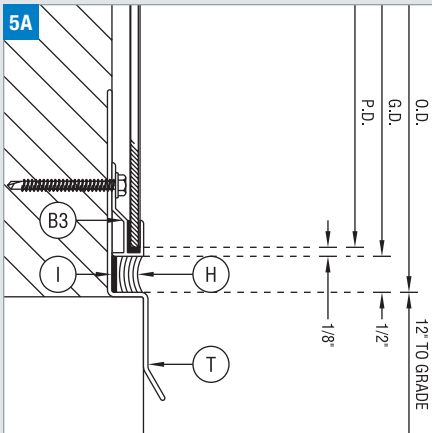

## WINDOW HEAD & SILL

### 5A & 5B: Head

Similar to the base condition, flashing should be used behind the system to direct water away and prevent moisture intrusion.

### 6A & 6B: Sill

Depending upon visual preference, windows will either extend past the face of the panel or be aligned so that they sit flush. If this is the last panel in the sequence, molding is held in place with sealant and adhesive.

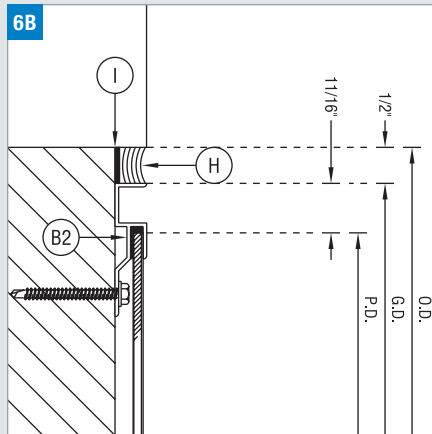
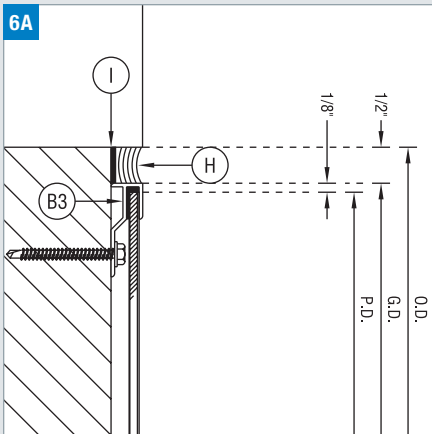

# LAYOUT AND INSTALLATION

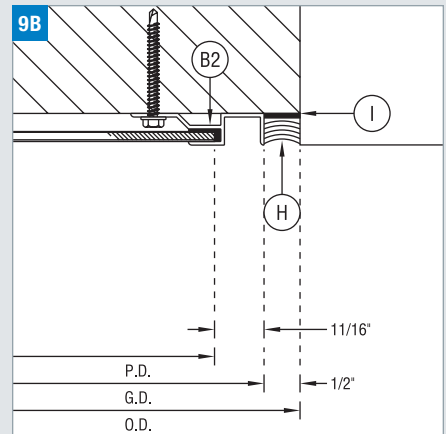
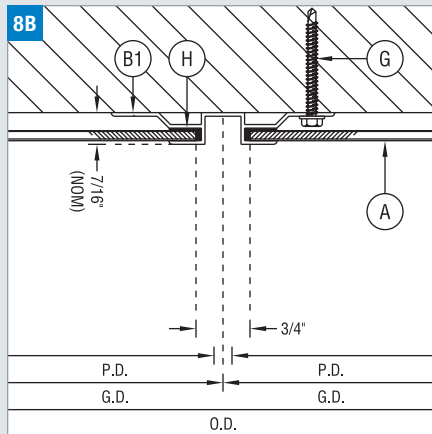
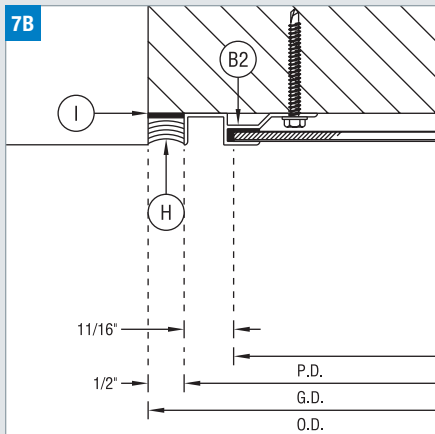
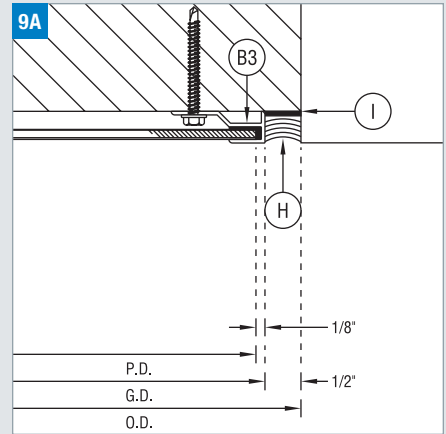
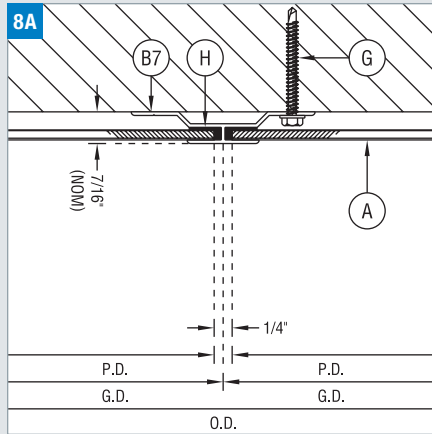
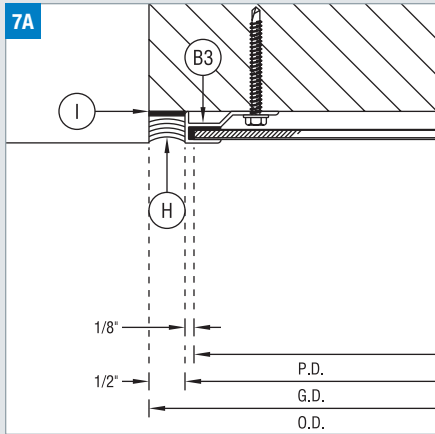

## VERTICAL SECTIONS

### 7A & 7B: Jamb - Start

When abutting dissimilar material, a sealant joint should be used to prevent moisture intrusion behind the system.

### 8A, 8B & 8C: Vertical

Same condition as the horizontal, the fastener is placed on the leading edge.

### 9A & 9B: Jamb - End

The last molding in the sequence will be held in place with visible fasteners or held in place with sealant and adhesive.

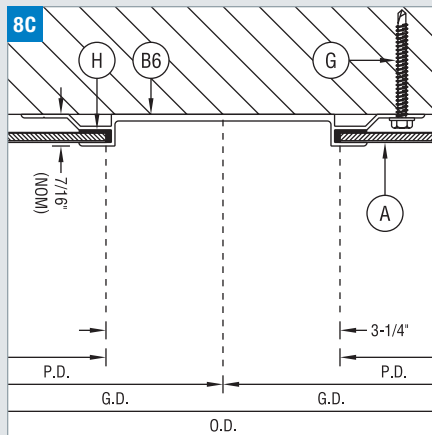

## OUTSIDE CORNER

### 10A, 10B & 10C: Outside Corner

The corner molding is slid over the panel edge after sealant has been applied. Then the lead leg is mechanically fastened. The next panel in the sequence is inserted into the molding after sealant is applied. As an option for non-standard corners (or for visual preference), the panels may be routed and bent to form the corner.

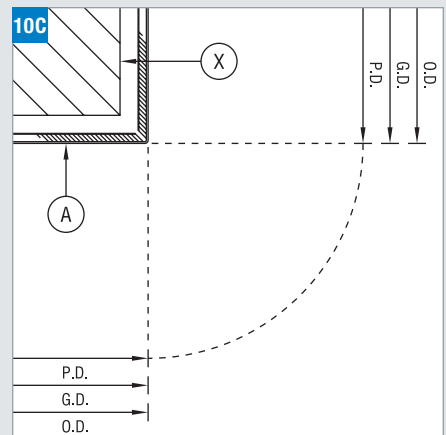
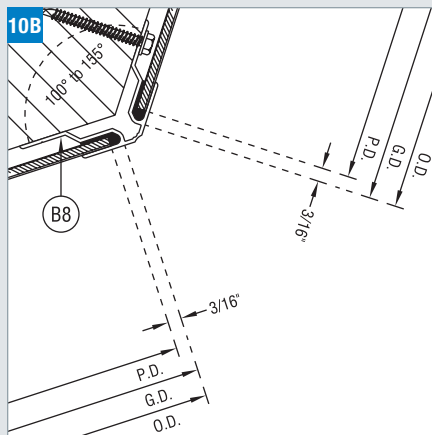
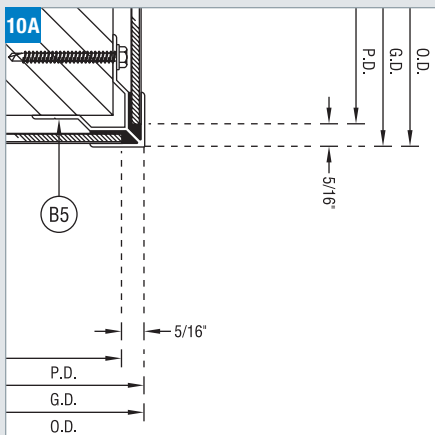

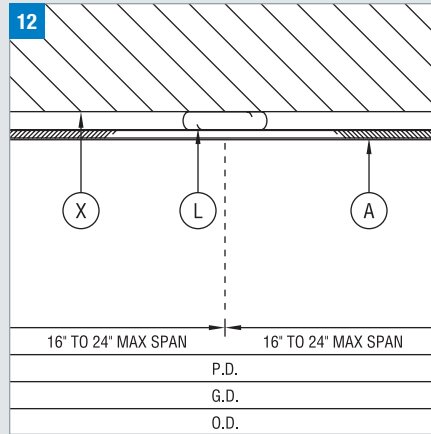
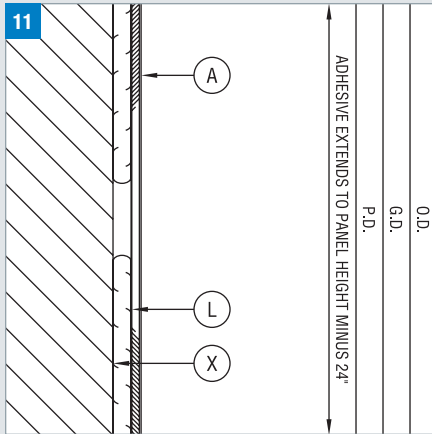

**INTERMEDIATE CONNECTION**

**11: Intermediate Connection - Horz**  
Construction adhesive secures the field of the panel at intermediate locations. The length of this bead should extend to cover a majority of the panel.

**12: Intermediate Connection - Vert**  
The spacing of the adhesive may be dependent upon the type of substrate chosen for the application.

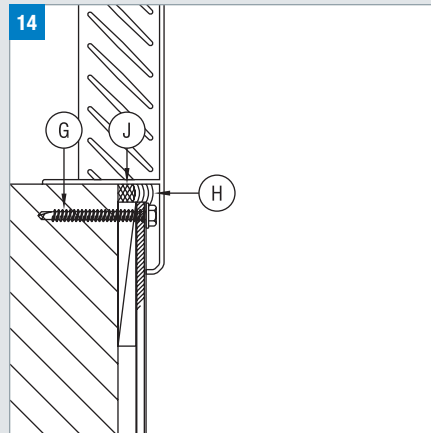
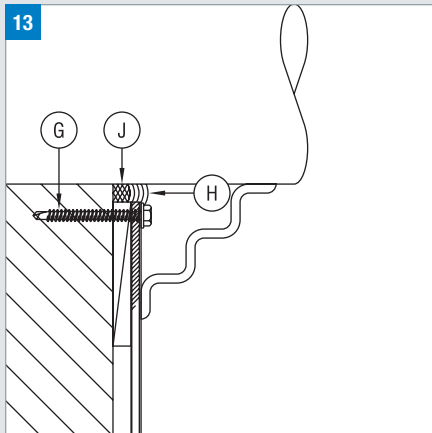

**SYSTEM PENETRATIONS**

**13: Round**  
When piping or other round penetrations must occur, the hole should be made slightly larger to accommodate a backer rod (when possible) and sealant joint around the object.

**14: Linear (Square or Rectangular)**  
Moldings should be used to trim the panel edge for all linear penetrations. However, if that is not possible, a proper sealant joint should be utilized to maintain system integrity.

**COMPONENTS**

- A** Envelope 2000
- B1** CR-AX1 Horizontal/Vertical (Reveal)
- B2** CR-AX2 Perimeter J (Reveal)
- B3** CR-AX3 Perimeter J
- B4** CR-AX4 Inside Corner
- B5** CR-AX5 Outside Corner
- B6** CR-AX6 Horizontal/Vertical (Reveal)
- B7** CR-AX7 Horizontal/Vertical
- B8** CR-AX8 Outside Corner (Adjustable)
- B9** CR-AX9 Inside Corner (Adjustable)
- G** Fastener  
As selected by contractor to suit project requirements.
  - Panel - secured by sealant/adhesive
  - Molding - 12" to 16" along length
- H** Silicone Sealant  
An approved sealant must be used. Contact Citadel for current list.
- I** Bond Breaker Tape
- J** Foam Backer Rod
- L** Construction Adhesive  
An approved adhesive must be used. Contact Citadel for current list.
  - Located 16" to 24" o.c.
  - 3/8" bead x 2/3 panel height
  - For panels 36" x 36" or larger
- T** Flashing
- X** Substrate  
As selected by architect to suit project requirements.

NOTE: Combine both SECTION and SUBSTRATE drawings for a complete listing of components.

# ENVELOPE 2000 REVEAL (RV) SYSTEM

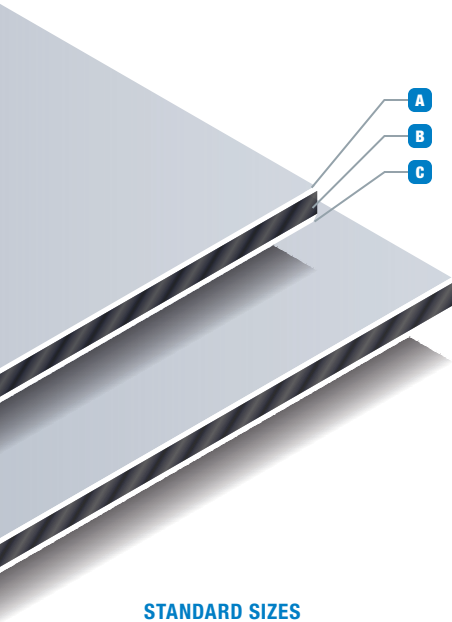

## STANDARD SIZES

48" x 96"	(121.9cm x 243.8cm)
48" x 120"	(121.9cm x 304.8cm)
48" x 144"	(121.9cm x 365.8cm)
60" x 96"	(152.4cm x 243.8cm)
60" x 120"	(152.4cm x 304.8cm)
60" x 144"	(152.4cm x 365.8cm)

Cut-to-size panels are available in any increment up to 60" x 144"

## WARRANTY

Panel Composition:	10 years
Kynar 500 Finishes:	30 years
Anodized Finishes:	20 years

## RECYCLED CONTENT (BY WEIGHT)

Post-Consumer:	0.5%
Post-Industrial:	23.3 to 23.9%

## BENDING / CURVING

Panels and moldings may be curved on-site (worked along a substrate) or in a factory setting.

Min. Radius On-Site:	25' (most applications)
Min. Radius Factory:	12"

## MATERIAL PROPERTIES

Component	Standard (in)	Metric (mm)
A. Prefinished Smooth Aluminum <sup>1</sup>	.024"	0.61mm
B. Thermoset Phenolic Resin	.105"	2.68mm
C. Primed Smooth Aluminum	.010"	0.25mm

## PANEL PROPERTIES

Property	Standard (in)	Metric (mm)
Panel Weight	1.25 lbs/ft <sup>2</sup>	6.12 kg/m <sup>2</sup>
Nominal Thickness <sup>2</sup>	1/8"	4mm
Thickness Tolerance	±1/32"	±0.79mm
Length & Width Tolerance	+0, -1/8"	+0, -3.18mm
Squareness	1/64" Per Lineal ft	
Flatness	Visually Flat	

## FINISH PROPERTIES

Finish	Type	Coating
Smooth Kynar 500®	2-coat PVDF (Solid, Mica)	0.20 mil Primer + 0.80 mil Color
	3-coat PVDF (Metallic)	0.20 mil Primer + 0.80 mil Color + 0.70 mil Clear
Smooth Anodized	Exterior Standard No. 1 <sup>3</sup>	0.20 mil to 0.45 mil (Depending on Color)

## PANEL PERFORMANCE<sup>4</sup>

Property	Test	Value	Unit
Flame Spread	ASTM E84	Class A	---
Peel Strength	ASTM D1781	34.5	lb-in/lb
Ignition Temperature	ASTM D1929	900°	°F
Impact Resistance	ASTM D5420	On Request	

## SYSTEM PERFORMANCE (ENVELOPE 2000 RV SYSTEM)

Property	Test	Value
Air Infiltration	ASTM E283	Pass
Water Resistance	ASTM E330	Pass
Uniform Load	ASTM E331	Pass

- 1 - Prefinished aluminum skins are furnished with a PVC film for protection during shipment and installation.
- 2 - 3mm, 6mm, and 8mm thicknesses are also available for use with other attachment systems.
- 3 - Class I or Class II anodizing is available as a premium custom finish. However, the warranty remains the same and fabrication difficulties will result (increased crazing, cracking) due to the increased film thickness.
- 4 - Other testing is available upon request.

## Citadel Architectural Products

6198 W Airport Blvd  
Greenfield, IN 46140  
(800) 446-8828

[www.citadelap.com](http://www.citadelap.com) • [info@citadelap.com](mailto:info@citadelap.com)



ISO 9001  
QMI-SAI Global  
#1501282



MADE IN THE U.S.A.