



**CITADEL**  
ARCHITECTURAL PRODUCTS

# ENVELOPE 2000<sup>®</sup>

DEEP-REVEAL (D-RV) SYSTEM

The Ultimate In Performance  
In A Hybrid-Type System

## TECHNICAL MANUAL

- System Assembly
- Substrate Layouts
- CAD Sections/Details
- Physical Properties
- Performance Properties



# SYSTEM ASSEMBLY



STANDARD JOINT



VARIABLE JOINT

## MOLDINGS / EXTRUSIONS

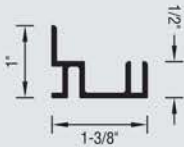

B1

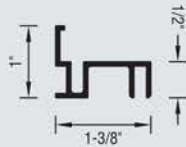

B2

## PROPERTIES

**B1** CRAX-10 Extrusion  
12'-6", 3.19 lbs

**B2** CRAX-11 Extrusion  
12'-6", 3.19 lbs

# LAYOUT AND INSTALLATION

## DESCRIPTION

- **Field Assembled** - all panels and moldings are shipped directly to the jobsite and are cut-to-size in the field, saving significant time and money
- **Cavity Wall (aka rainscreen)** - incidental moisture is allowed to enter the system but then is channeled out through weep holes
- **Progressive** - each step of the installation process builds off the previous step in a sequential manner, moving up and across the elevation
- **Joints** - two individual extrusions trim out the panel edge while a small accent strip (panel) floats in place and completes the appearance of the joint

### Comparative Installed Cost



\$ (compared to other Citadel systems) \$\$

**Lead Time:** 15 working days  
**Minimum Qty:** none  
**System Depth:** 1-5/16" from the face of the substrate to the face of the molding

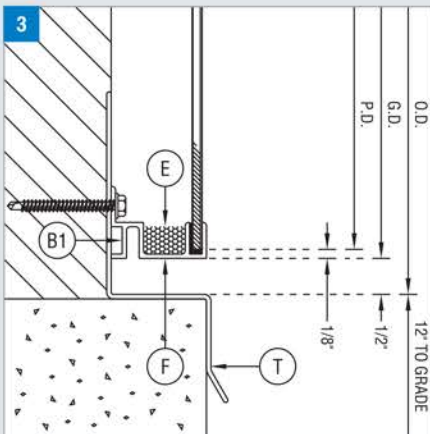
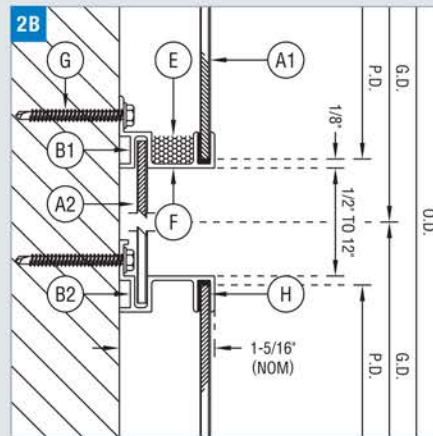
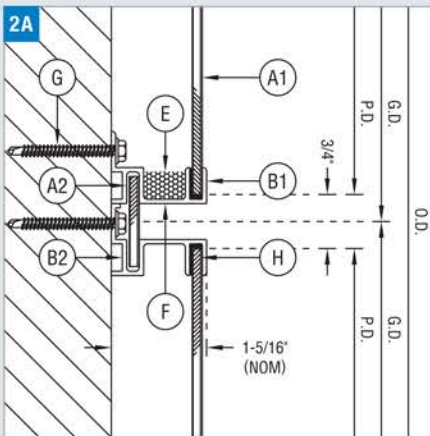
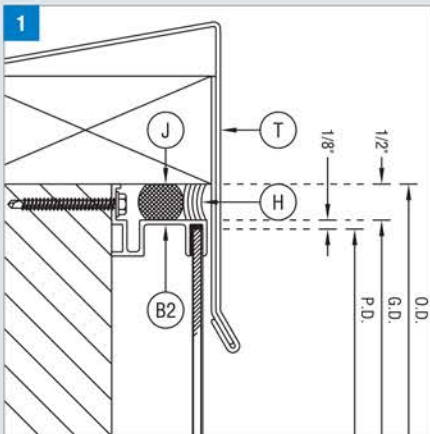

## HORIZONTAL SECTIONS

### 1: Parapet

Metal flashing secured over blocking completes the vertical run and prevents moisture from getting behind the cladding system.

### 2A & 2B: Horizontal

Sealant is applied into the molding channel and slid over the top of the panel. The extrusion is mechanically fastened to the substrate. The accent strip (panel) is then inserted and 'floats' (no sealant) within the extrusion. The next molding is then secured to complete the joint. Joint may vary from 1/2" to 12".

### 3: Base/Foundation

Installation typically begins at the base of the wall and moves vertically. The cladding should be kept approximately 12" away from landscaping grade. However, if the system is installed adjacent to a concrete sidewalk, that dimension may be reduced to 1/2".

## INSIDE CORNER

### 4: Inside Corner

There are a number of different methods for addressing the corner condition. The most common is routing the back of the panel and bending it around the corner.

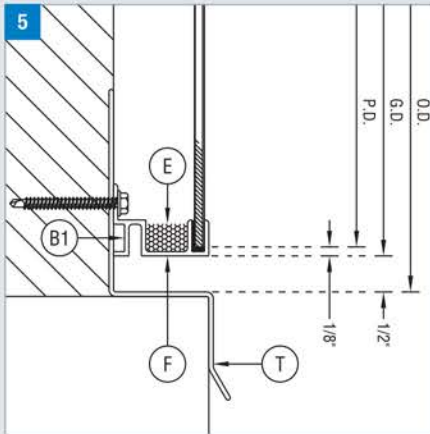
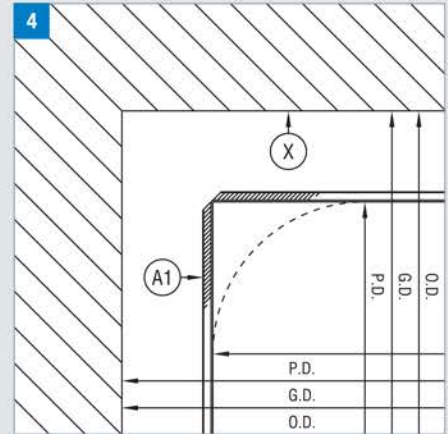

## WINDOW HEAD & SILL

### 5: Head

Similar to the base condition, flashing should be used behind the system to direct water away from the system. Weep holes in the bottom of the molding allow any moisture that may have entered the system to escape. The holes are covered on the back side by a foam baffle.

### 6: Sill

Depending upon visual preference, windows will either extend past the face of the panel or be aligned so that they sit flush. A sealant joint conceals the fastener and prevents excessive water from entering the cladding cavity.

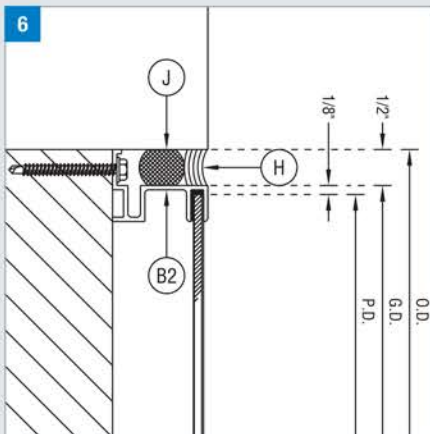



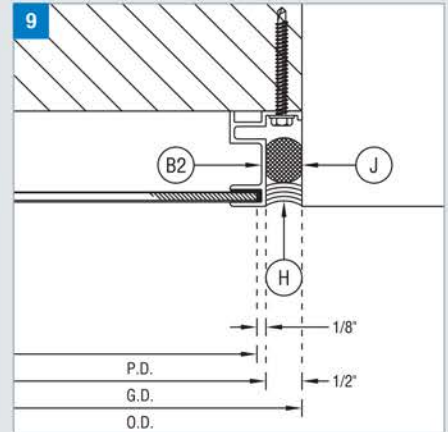
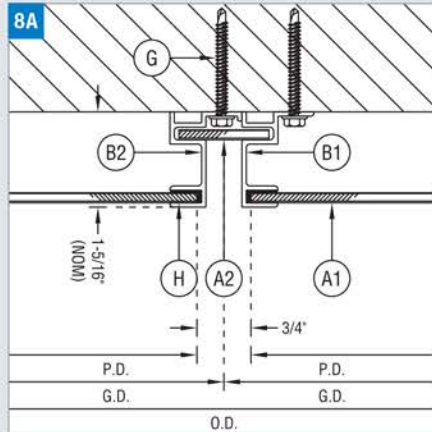
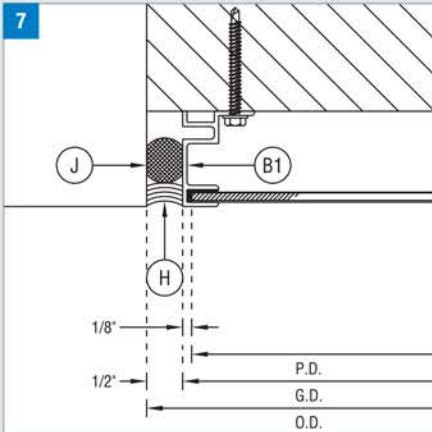

## VERTICAL SECTIONS

### 7 & 9: Jamb

When abutting dissimilar material, a sealant joint should be used to prevent excessive water from entering the cladding system.

### 8A & 8B: Vertical

Same condition as the horizontal with the exception of the weep hole and baffle foam. In the vertical plane, these items are not required.

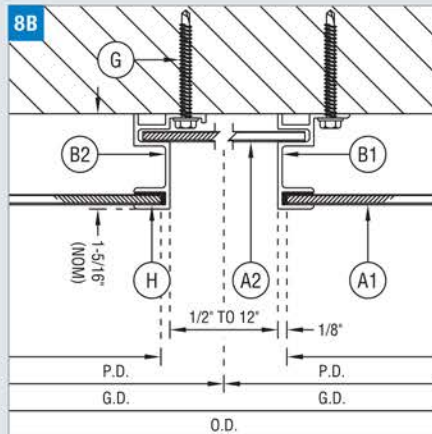

## OUTSIDE CORNER

### 10: Outside Corner

Similar to the inside corner, there are a number of different methods for addressing the outside corner condition. The most common is routing the back of the panel and bending it around the corner.

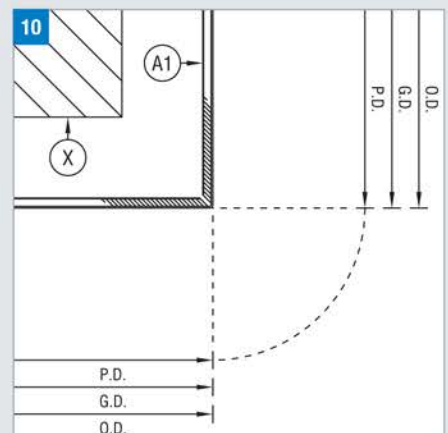

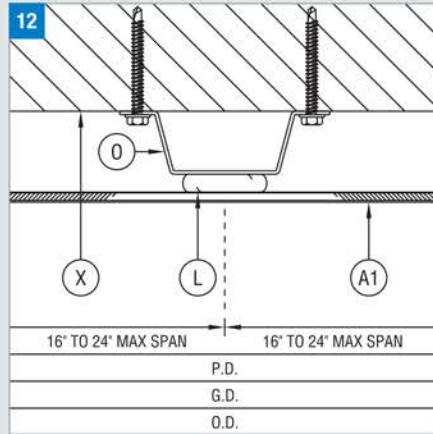
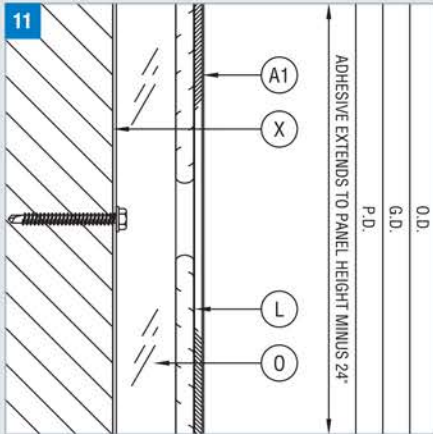

## INTERMEDIATE CONNECTION

### 11: Intermediate Connection - Horiz

Due to the system depth, hat channels or z-girts must be placed within the field of the panel. Construction adhesive secures the field of the panel at intermediate locations. The length of this bead should extend to cover a majority of the panel.

### 12: Intermediate Connection - Vert

The spacing of the supports (and adhesive) may be dependent upon the type of substrate chosen for the application.

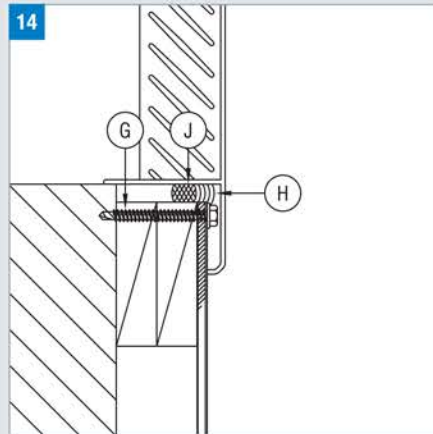
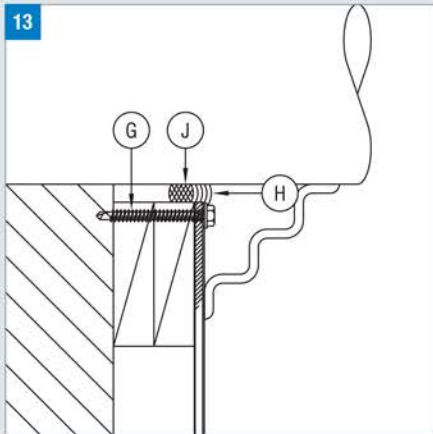

## SYSTEM PENETRATIONS

### 13: Round

When piping or other round penetrations must occur, the hole should be made slightly larger to accommodate a backer rod (when possible) and sealant joint around the object.

### 14: Linear (Square or Rectangular)

Moldings should be used to trim the panel edge for all linear penetrations. However, if that is not possible, a proper sealant joint should be utilized to prevent excessive water from entering the system.

## COMPONENTS

- A1** Envelope 2000®
- A2** Spline (Envelope 2000®)
- B1** CR-AX10 Extrusion
- B2** CR-AX11 Extrusion
- E** Weep Baffle  
Placed on the inside of the weep hole to prevent debris from entering system.
- F** Weep Hole
  - 1/4" x 3/4" elongated round hole
  - 2 (min) per panel regardless of size
- G** Fastener  
As selected by contractor to suit project requirements.
  - panel - secured by sealant/adhesive
  - molding - 12" to 16" along length
- H** Silicone Sealant  
An approved sealant must be used. Contact Citadel for current list.
- I** Bond Breaker Tape
- J** Foam Backer Rod
- L** Construction Adhesive  
An approved adhesive must be used. Contact Citadel for current list.
  - located 16" to 24" o.c.
  - 3/8" bead x 2/3 panel height
- O** Field Support
  - metal (hat channels, z-girts) or wood
  - located 16" to 24" o.c.
  - for panels 36" x 36" or larger
  - length to be 2/3 panel height
  - fastened 12" to 16" along length
- T** Flashing
- X** Substrate  
As selected by architect to suit project requirements.

NOTE: Combine both SECTION and SUBSTRATE drawings for a complete listing of components.

## NAILABLE SUBSTRATE

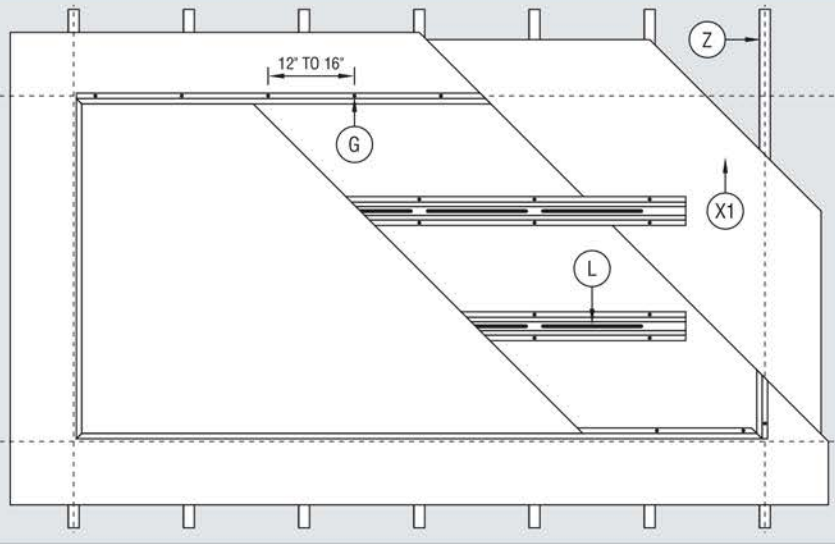

## NON-NAILABLE SUBSTRATE

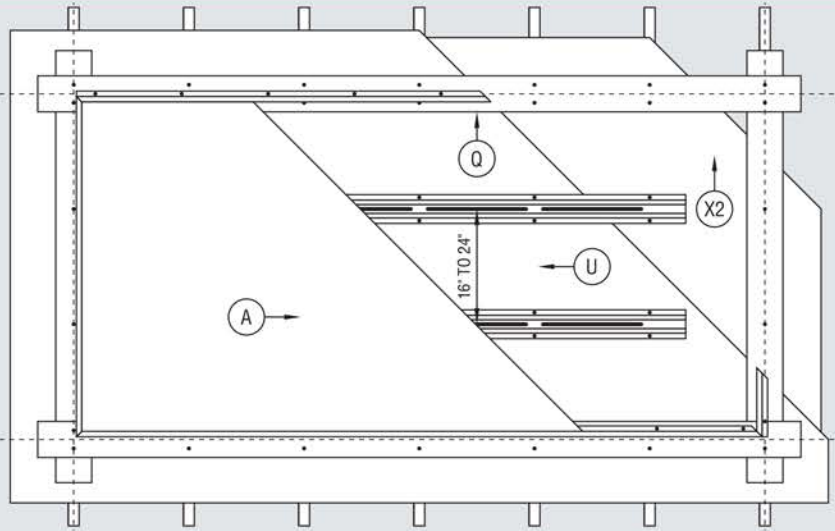

## MASONRY SUBSTRATE

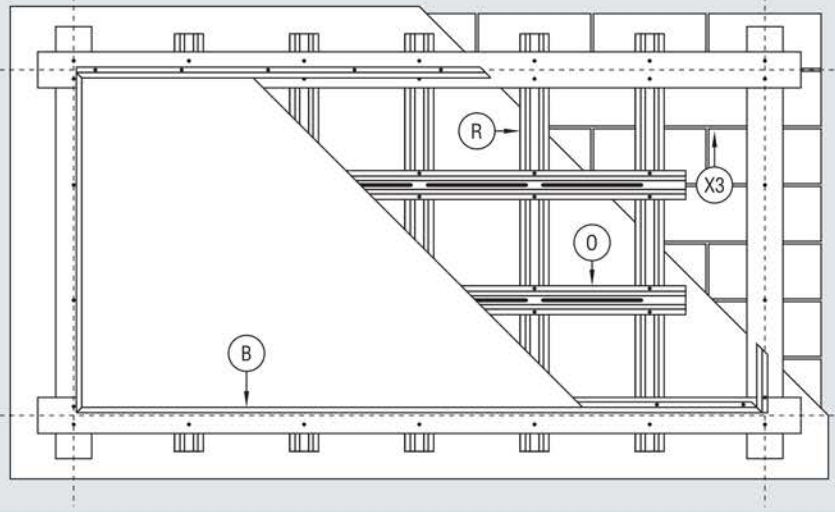

## COMPONENTS

- A** Envelope 2000®
- B** Molding
- G** Fastener  
As selected by contractor to suit project requirements.
  - panel - secured by sealant/adhesive
  - molding - 12" to 16" along length
- L** Construction Adhesive  
An approved adhesive must be used. Contact Citadel for current list.
  - located 16" to 24" o.c.
  - 3/8" bead x 2/3 panel height
- O** Field Support
  - metal (hat channels, z-girts) or wood
  - located 16" to 24" o.c.
  - length to be 2/3 panel width
  - fastened 12" to 16" along length
  - for panels 36" x 36" or larger
- Q** Grid Strapping
  - 16ga (min) recommended
  - fastened 12" to 16" along length
- R** Furring
  - metal (hat channels, z-girts) or wood
  - located 16" to 24" o.c.
  - fastened 12" to 16" along length
- S** Shim (not shown)
  - plastic shims recommended
  - flatness tolerance is 1/4" in 20'-0"
- U** Air/Moisture Barrier  
Required for this system.
- X1** Nailable Substrate
  - plywood - 1/2" (min) recommended
  - OSB - 1/2" (min) recommended
- X2** Non-Nailable Substrate
  - exterior gypsum board
- X3** Masonry Substrate
  - CMU (block)
  - pre-formed concrete
- Z** Stud Framework
  - metal or wood
  - located 16" to 24" o.c.

NOTE: Combine both SECTION and SUBSTRATE drawings for a complete listing of components.



# ENVELOPE 2000® DEEP-REVEAL (D-RV) SYSTEM



## STANDARD SIZES

48" x 96"	(121.9cm x 243.8cm)
48" x 120"	(121.9cm x 304.8cm)
48" x 144"	(121.9cm x 365.8cm)
60" x 96"	(152.4cm x 243.8cm)
60" x 120"	(152.4cm x 304.8cm)
60" x 144"	(152.4cm x 365.8cm)

Cut-to-size panels are available in any increment up to 60" x 144".

## WARRANTY

Panel Composition:	5 years
Kynar 500® Finishes:	30 years
Anodized Finishes:	20 years

## RECYCLED CONTENT (BY WEIGHT)

Post-Consumer:	0.5%
Post-Industrial:	23.3% to 23.9%

## BENDING / CURVING

Panels and moldings may be curved on-site (worked along a substrate) or in a factory setting.

Min. Radius On-Site:	25' (most applications)
Min. Radius Factory:	12"

## MATERIAL PROPERTIES

Component	Standard (in)	Metric (mm)
A Prefinished Smooth Aluminum <sup>1</sup>	.024"	0.61mm
B Thermoset Phenolic Resin	.105"	2.68mm
C Primed Smooth Aluminum	.010"	0.25mm

## PANEL PROPERTIES

Property	Standard (in)	Metric (mm)
Panel Weight	1.25 lbs/ft <sup>2</sup>	6.12 kg/m <sup>2</sup>
Nominal Thickness <sup>2</sup>	1/8"	4mm
Thickness Tolerance	±1/32"	±0.79mm
Length & Width Tolerance	+0, -1/8"	+0, -3.18mm
Squareness	1/64" per lineal ft	
Flatness	visually flat	

## FINISH PROPERTIES

Finish	Type	Coating
Smooth Kynar 500®	2-coat PVDF (solid, mica)	0.20 mil primer + 0.80 mil color
	3-coat PVDF (metallic)	0.20 mil primer + 0.80 mil color + 0.70 mil clear
Smooth Anodized	Exterior Standard No. 1 <sup>3</sup>	0.20 mil to 0.45 mil (depending on color)

## PANEL PERFORMANCE<sup>4</sup>

Property	Test	Value	Unit
Flame Spread	ASTM E84	Class A	---
Peel Strength	ASTM D1781	34.5	lb-in/lb
Ignition Temperature	ASTM D1929	900°	°F
Impact Resistance	ASTM D5420	on request	

## SYSTEM PERFORMANCE (ENVELOPE 2000® D-RV SYSTEM)

Property	Test	Value
Air Infiltration	ASTM E283	pass
Water Resistance	ASTM E330	pass
Uniform Load	ASTM E331	pass

- 1 - Prefinished aluminum skins are furnished with a PVC film for protection during shipment and installation.
- 2 - 3mm, 6mm, and 8mm thicknesses are also available for use with other attachment systems.
- 3 - Class I or Class II anodizing is available as a premium custom finish. However, the warranty remains the same and fabrication difficulties will result (increased crazing, cracking) due to the increased film thickness.
- 4 - Other testing is available upon request.

**Citadel Architectural Products, Inc.**  
 3131-A North Franklin Road  
 Indianapolis, Indiana 46226  
 phone (317) 894-9400 • (800) 446-8828  
 fax (317) 894-6333 • (800) 247-2635  
[www.citadelap.com](http://www.citadelap.com) • [info@citadelap.com](mailto:info@citadelap.com)

