



**CITADEL**  
ARCHITECTURAL PRODUCTS

Economical Durability  
With Low-Profile Moldings

#### TECHNICAL MANUAL

- System Assembly
- Substrate Layouts
- CAD Sections/Details
- Physical Properties
- Performance Properties

## PANEL 15<sup>®</sup>

TWO PIECE MOLDING SYSTEM



# SYSTEM ASSEMBLY



BATTEN PROFILES



REVEAL PROFILES

## MOLDINGS / EXTRUSIONS

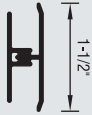

B1

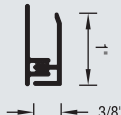

B2

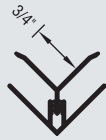

B3

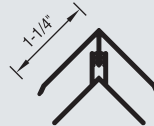

B4

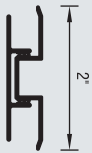

B5

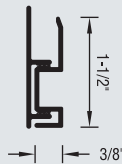

B6

## PROPERTIES

**B1** ST601MX Horizontal/Vertical  
R20-401 Receiver  
10'-0", 1.20 lbs / 12'-0", 0.72 lbs

**B2** ST603MX Perimeter J  
R20-403 Receiver  
10'-0", 1.05 lbs / 12'-0", 0.72 lbs

**B3** ST605MX Inside Corner  
R20-404 Receiver  
10'-0", 1.20 lbs / 12'-0", 0.90 lbs

**B4** ST607MX Outside Corner  
R20-405 Receiver  
10'-0", 2.10 lbs / 12'-0", 0.90 lbs

**B5** SR701MX Horizontal/Vertical (Reveal)  
R20-406 Receiver  
10'-0", 1.65 lbs / 12'-0", 1.08 lbs

**B6** SR703MX Perimeter J (Reveal)  
R20-407 Receiver  
10'-0", 1.65 lbs / 12'-0", 0.90 lbs

## NAILABLE SUBSTRATE

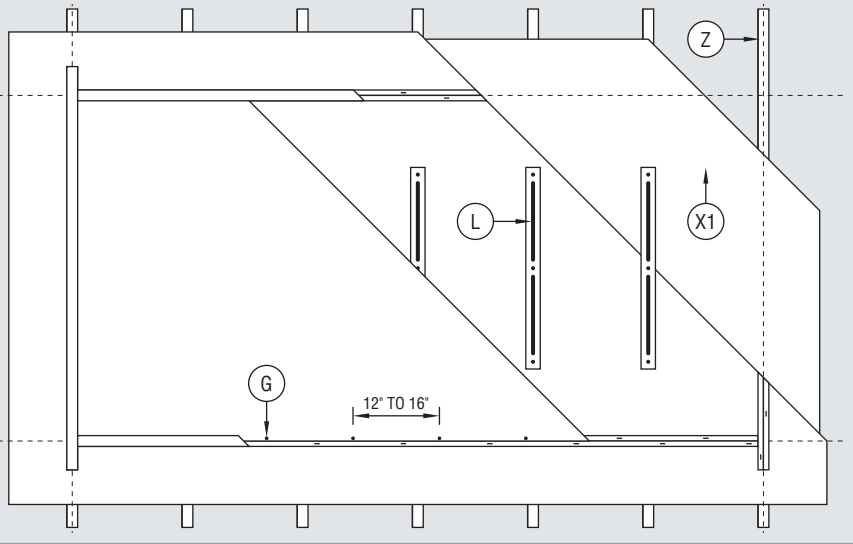

## NON-NAILABLE SUBSTRATE

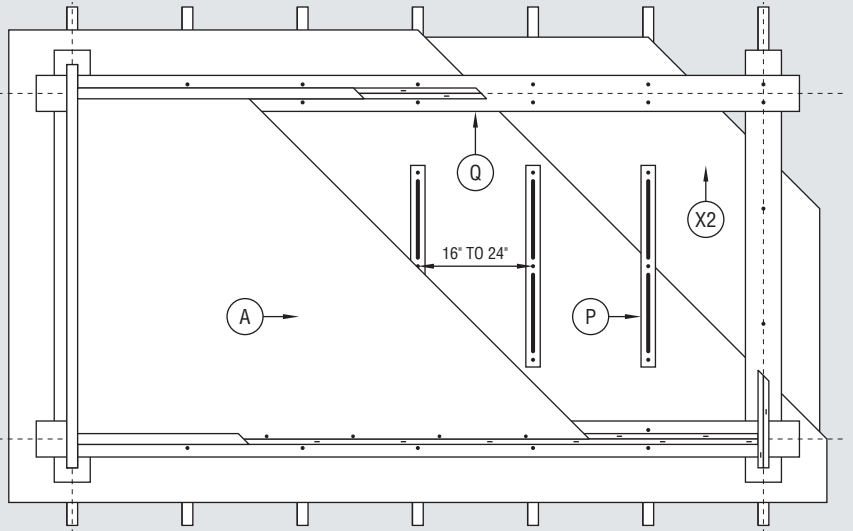

## MASONRY SUBSTRATE

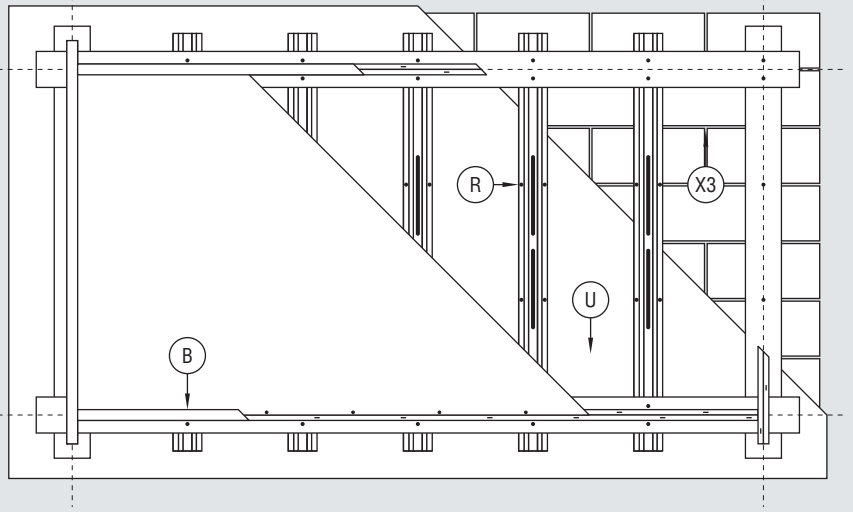

## COMPONENTS

- A** Panel 15®
- B** Two Piece Molding
- G** Fastener  
As selected by contractor to suit project requirements.
  - cover - snap into receivers
  - receiver - 12" to 16" along length
  - panel - 12" to 16" around perimeter
- L** Construction Adhesive  
An approved adhesive must be used. Contact Citadel for current list.
  - located 16" to 24" o.c.
  - 3/8" bead x 2/3 panel height
  - double-sided tape as alternate
  - for panels 36" x 36" or larger
- P** Field Strapping
  - located 16" to 24" o.c.
  - 1-1/2" (min) x 2/3 panel height
  - 22ga (min) recommended
  - fastened 12" to 16" along length
- Q** Grid Strapping
  - 16ga (min) recommended
  - fastened 12" to 16" along length
- R** Furring
  - metal (hat channels, z-girts) or wood
  - located 16" to 24" o.c.
  - fastened 12" to 16" along length
- S** Shim (not shown)
  - plastic shims recommended
  - flatness tolerance is 1/4" in 20'-0"
- U** Air/Moisture Barrier  
Recommended for this system.
- X1** Nailable Substrate
  - plywood - 1/2" (min) recommended
  - OSB - 1/2" (min) recommended
- X2** Non-Nailable Substrate
  - exterior gypsum board
- X3** Masonry Substrate
  - CMU (block)
  - pre-formed concrete
- Z** Stud Framework
  - metal or wood
  - located 16" to 24" o.c.

NOTE: Combine both SECTION and SUBSTRATE drawings for a complete listing of components.

# LAYOUT AND INSTALLATION

## DESCRIPTION

- **Field Assembled** - all panels and moldings are shipped directly to the jobsite and are cut-to-size in the field, saving significant time and money
- **Barrier Wall** - designed to be completely sealed against moisture intrusion to protect the structural wall assembly of the building
- **Non-Progressive** - due the manner in which the plastic receivers and aluminum covers are applied, work may begin in any part of the elevation
- **Joints** - plastic receivers and low-profile, aluminum covers make up the two piece moldings that complete the trim, batten and reveal profiles

### Comparative Installed Cost



**Lead Time:** 15 working days  
**Minimum Qty:** none  
**System Depth:** 1/2" from the face of the substrate to the face of the molding

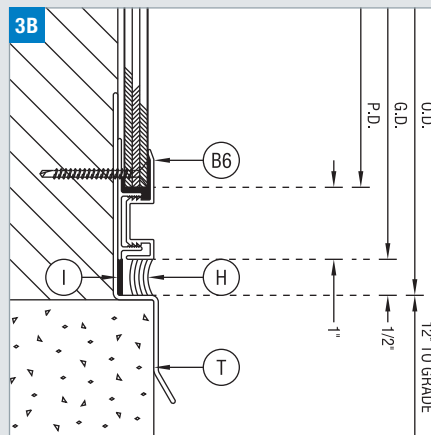
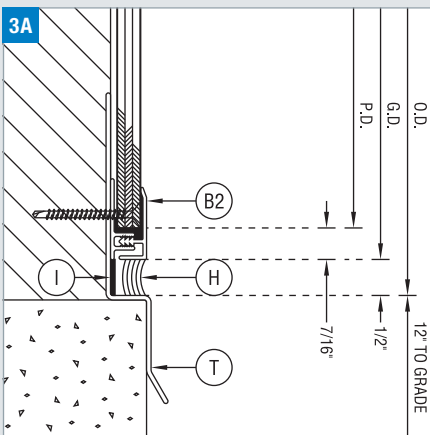
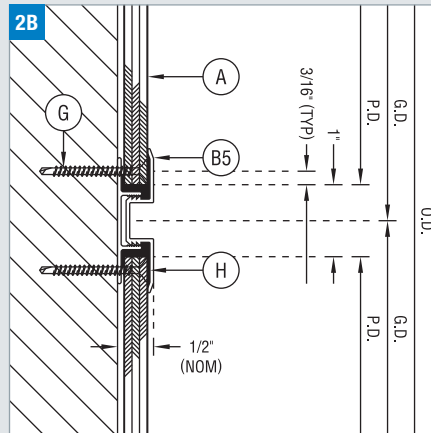
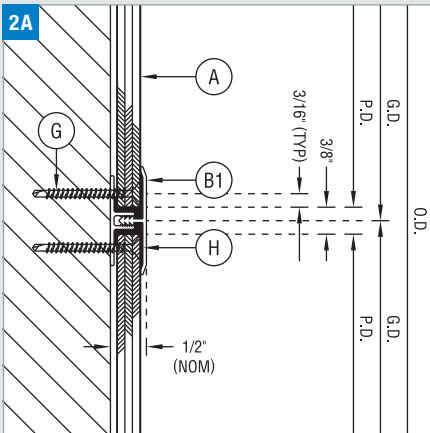
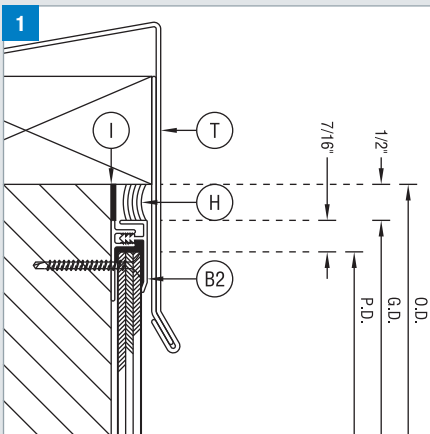

## HORIZONTAL SECTIONS

### 1: Parapet

Metal flashing secured over blocking completes the vertical run and prevents moisture from getting behind the cladding system.

### 2A & 2B: Horizontal

Plastic receivers are first secured in place with brads or nails. Then the panel is applied and mechanically fastened. Sealant is then liberally applied and the aluminum cover is snapped into place. Batten and reveal (1/2") profiles are available.

### 3A & 3B: Base/Foundation

Installation typically begins at the base of the wall and moves vertically. The cladding should be kept approximately 12" away from landscaping grade. However, if the system is installed adjacent to a concrete sidewalk, that dimension may be reduced to 1/2".

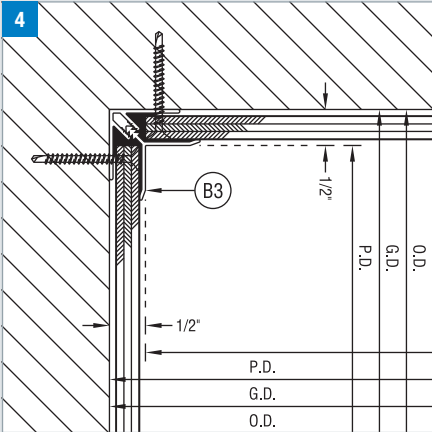

## INSIDE CORNER

### 4: Inside Corner

Typically, corners are completed with the standard two-piece profile. For corners that are out of square or irregular, two perimeter moldings may be used to form the correct angle. This condition is also applicable for soffit to wall transitions.

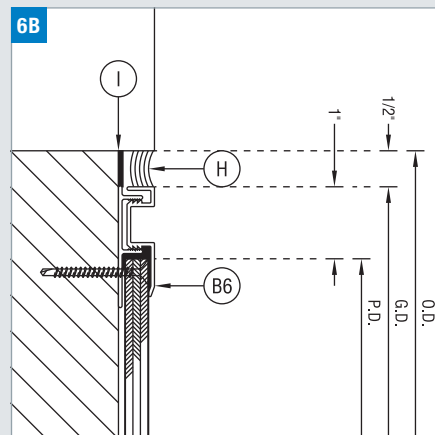
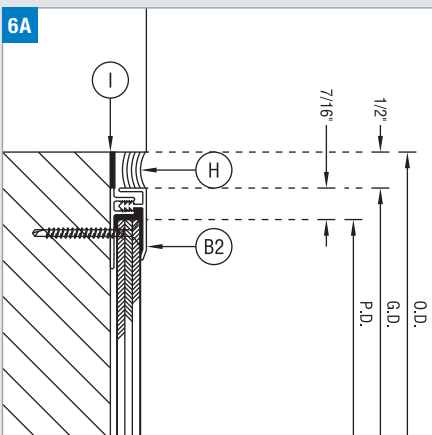
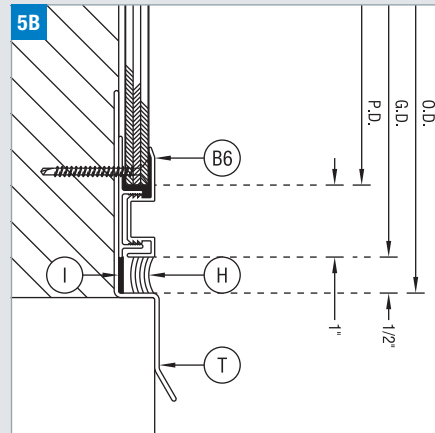
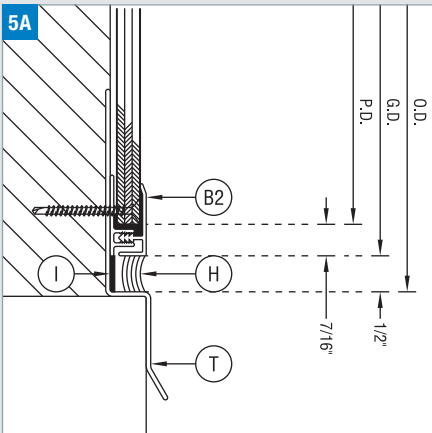

## WINDOW HEAD & SILL

### 5A & 5B: Head

Similar to the base condition, flashing should be used behind the system to direct water away and prevent moisture intrusion.

### 6A & 6B: Sill

Depending upon visual preference, windows will either extend past the face of the panel or be aligned so that they sit flush. Batten or reveal profiles may be used for this condition.

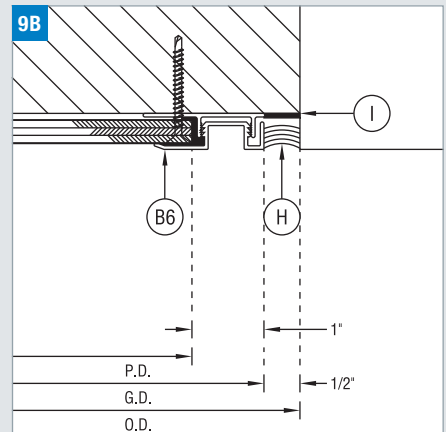
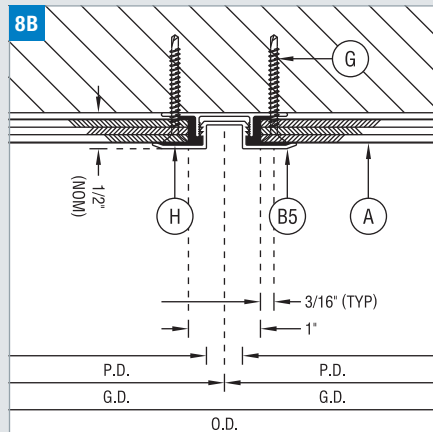
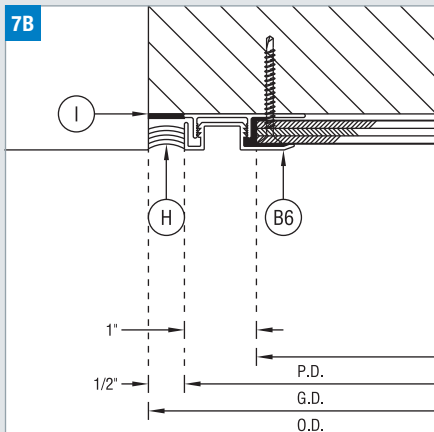
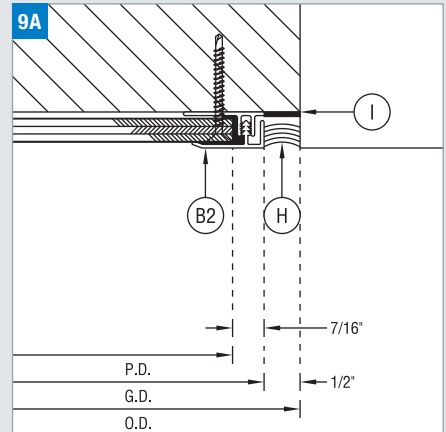
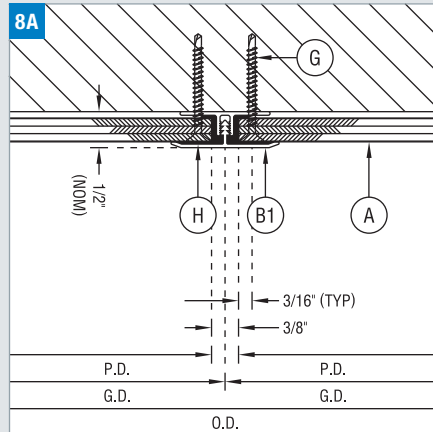
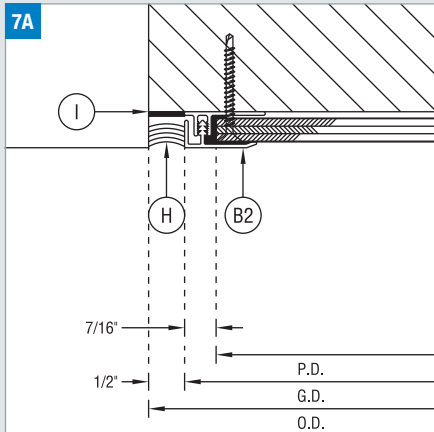

## VERTICAL SECTIONS

### 7A, 7B & 9A, 9B: Jamb

When abutting dissimilar material, a sealant joint should be used to prevent moisture intrusion behind the cladding system.

### 8A & 8B: Vertical

Same condition as the horizontal, the receiver is secured in place, followed by the panel, then the sealant and the aluminum cover. Batten and reveal profiles.

## OUTSIDE CORNER

### 10: Outside Corner

Similar to the inside corner, the standard molding can be used for typical corners. If preferred, two perimeter moldings can be used instead. This condition is also applicable for fascia to soffit transitions.

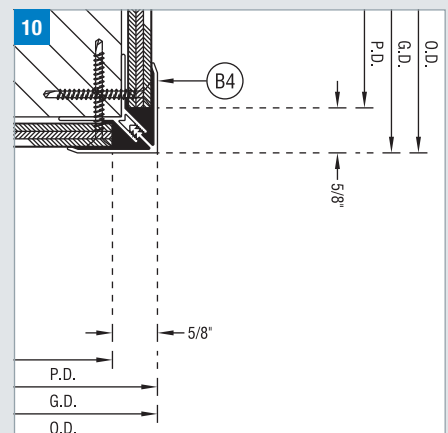

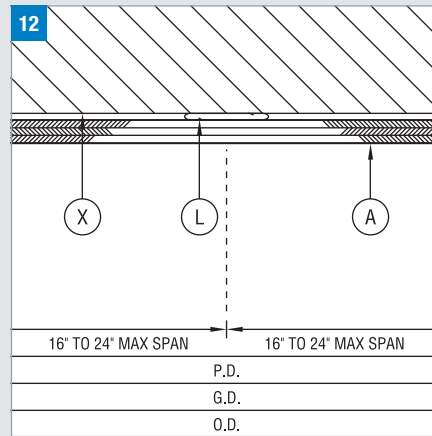
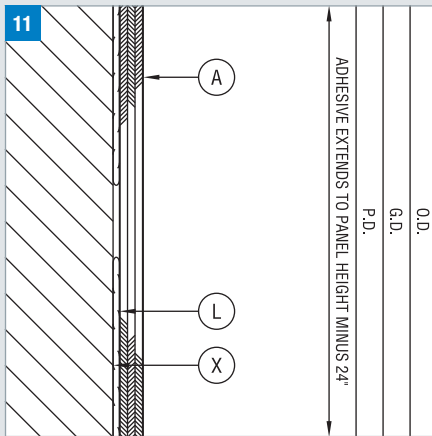

## INTERMEDIATE CONNECTION

### 11: Intermediate Connection - Horiz

Construction adhesive secures the field of the panel at intermediate locations. The length of this bead should extend to cover a majority of the panel.

### 12: Intermediate Connection - Vert

The spacing of the adhesive may be dependent upon the type of substrate chosen for the application.

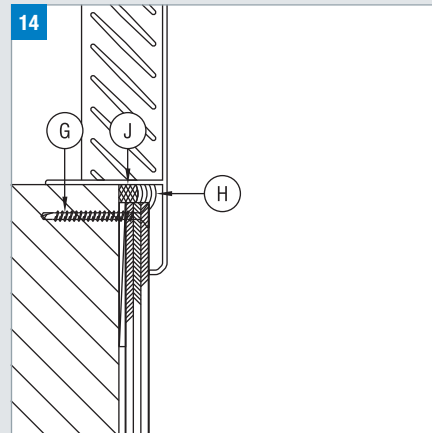
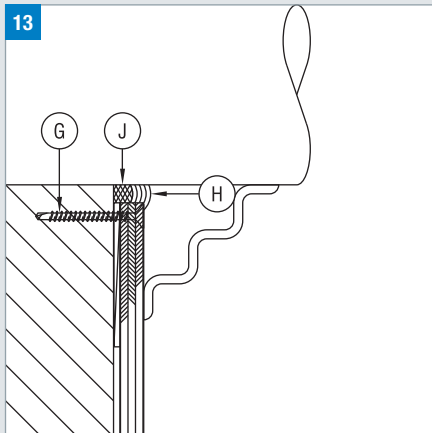

## SYSTEM PENETRATIONS

### 13: Round

When piping or other round penetrations must occur, the hole should be made slightly larger to accommodate a backer rod (when possible) and sealant joint around the object.

### 14: Linear (Square or Rectangular)

Moldings should be used to trim the panel edge for all linear penetrations. However, if that is not possible, a proper sealant joint should be utilized to maintain system integrity.

## COMPONENTS

- A** Panel 15®
- B1** ST-601MX Horizontal/Vertical R20-401 Receiver
- B2** ST-603MX Perimeter J R20-403 Receiver
- B3** ST-605MX Inside Corner R20-404 Receiver
- B4** ST-607MX Outside Corner R20-405 Receiver
- B5** SR-701MX Horizontal/Vertical (Reveal) R20-406 Receiver
- B6** SR-703MX Perimeter J (Reveal) R20-407 Receiver
- G** Fastener  
As selected by contractor to suit project requirements.
  - cover - snap into receivers
  - receiver - 12" to 16" along length
  - panel - 12" to 16" around perimeter
- H** Silicone Sealant  
An approved sealant must be used.  
Contact Citadel for current list.
- I** Bond Breaker Tape
- J** Foam Backer Rod
- L** Construction Adhesive  
An approved adhesive must be used.  
Contact Citadel for current list.
  - located 16" to 24" o.c.
  - 3/8" bead x 2/3 panel height
  - double-sided tape as alternate
  - for panels 36" x 36" or larger
- T** Flashing
- X** Substrate  
As selected by architect to suit project requirements.

NOTE: Combine both SECTION and SUBSTRATE drawings for a complete listing of components.

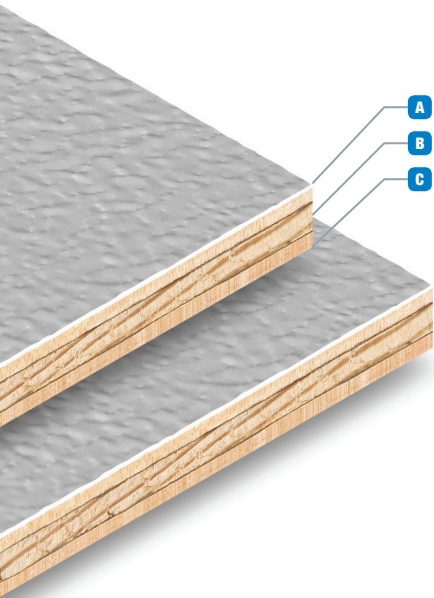

# PANEL 15<sup>®</sup> TWO PIECE MOLDING SYSTEM

MATERIAL PROPERTIES		
Component	Standard (in)	Metric (mm)
<b>A</b> Prefinished Textured Aluminum <sup>1</sup>	.010"	0.25mm
<b>B</b> Douglas Fir Plywood	5/16"	7.94mm
<b>C</b> Fiberglass Reinforced Foil	.008"	0.20mm

PANEL PROPERTIES		
Property	Standard (in)	Metric (mm)
Panel Weight	1.01 lbs/ft <sup>2</sup>	4.93 kg/m <sup>2</sup>
Nominal Thickness	5/16"	7mm
Thickness Tolerance	±1/32"	±0.79mm
Length & Width Tolerance	+0, -1/8"	+0, -3.18mm
Squareness	1/64" per lineal ft	
Flatness	slight camber from factory, flat once installed	

FINISH PROPERTIES		
Finish	Type	Coating
Textured Polyester	1-coat	0.80 mil color

PANEL PERFORMANCE			
Property	Test	Value	Unit
Flame Spread	ASTM E84	Class A	---

## STANDARD SIZES

- 48" x 96" (121.9cm x 243.8cm)
- 48" x 120" (121.9cm x 304.8cm)
- 48" x 144" (121.9cm x 365.8cm)
- 60" x 96" (152.4cm x 243.8cm)
- 60" x 120" (152.4cm x 304.8cm)

Cut-to-size panels are available in any increment up to 60" x 120".

## WARRANTY

- Panel Composition: 5 years
- Polyester Finishes: 5 years

## RECYCLED CONTENT (BY WEIGHT)

- Post-Consumer: 0.4%
- Post-Industrial: 5.0%

<sup>1</sup> - Prefinished aluminum skins are furnished with a PVC film for protection during shipment and installation.

**Citadel Architectural Products, Inc.**  
 3131-A North Franklin Road  
 Indianapolis, Indiana 46226  
 phone (317) 894-9400 • (800) 446-8828  
 fax (317) 894-6333 • (800) 247-2635  
[www.citadelap.com](http://www.citadelap.com) • [info@citadelap.com](mailto:info@citadelap.com)

